

Twinhorn®

tüv
CERT
DIN EN ISO 9002

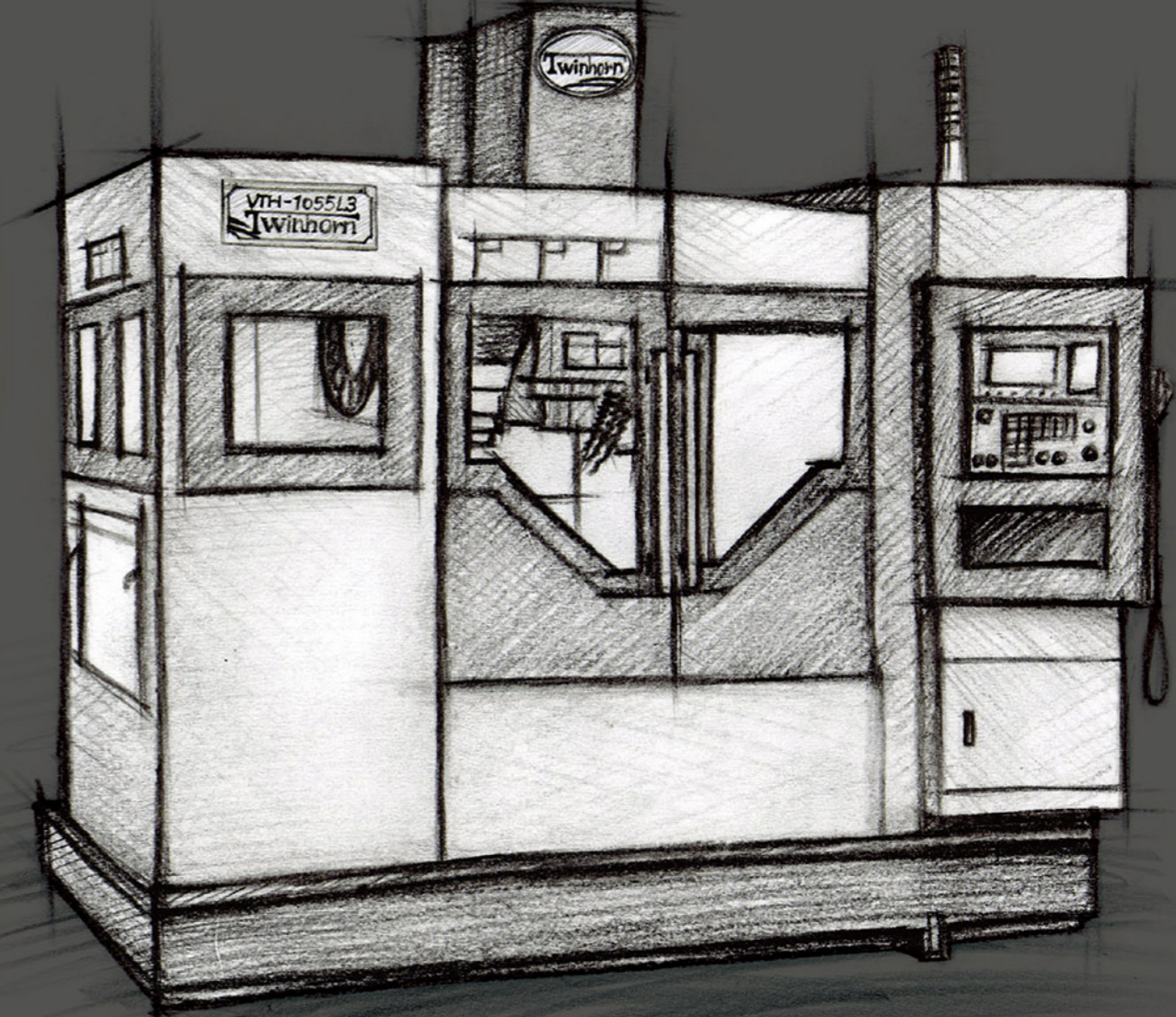
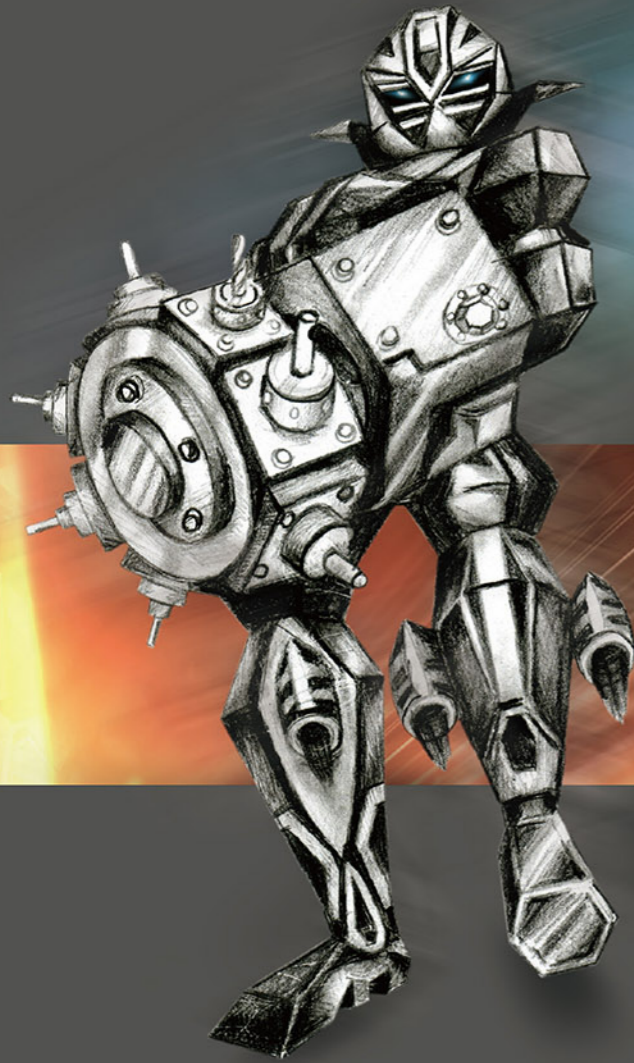

Twinhorn

CHI-FA MACHINERY MANUFACTURER CO., LTD.

No. 44-8, MING-CHUNG RD., SHENG-KANG DIST.,
TAICHUNG CITY, TAIWAN 42948

Tel: +886-4-2562-8747 (Rep.)

Fax: +886-4-2561-4199

E-mail: inquiry@twinhorn.com.tw

www.twinhorn.com.tw



MTT
TECHNOLOGY

MTT Technology S.r.l

Via Vegri, 29-36047 Montegalda (VI), Italy

T +39 044 4737371

M+39 388 0553230

info@mtt-technology.it

sales@mtt-technology.it

www.mtt-technology.it



Design 201806_VTH Series(E3)1000P

VTH-1055L3/1060L3
VTH-1055F

VERTICAL MACHINING CENTER
FIVE AXIS MACHINING CENTER

VTH Series

Mechanical Features

- All major parts are built with high tensile Meehanite FC 30 casting alloy provides outstanding wear-resistance and rigidity.
- High precision D40 mm, C3 class ball-screw with double nut pre-tension design on all three axes to enhance axis rigidity and accuracy stability.
- Extra widened separated guide ways design on base.
- Counter weightless design, upgraded direct driven Z axis motor provide the best reaction on high speed movement.
- Three axes adapts linear guide ways: X / Y / Z : 35 / 45 / 45 mm. Z axis equipped with extra length carriage to enhance stability.

The innovative design of high-performance high-precision

Guide way cover

- Enlarged single piece of guide way cover on the rear side of Y axis with big slop design for best chip collect and remove.
- Big slop design on the front side of Y axis
- Widen design on X axis to fully cover the limit switch and optical scales device.

Fully splash guard

- Provides safety machining enviroment and highly efficient chip removal functions.

ATC System

- High accuracy CAM driven tool exchange system has most stable and efficient automatic tool management.

Twinhorn
High-quality

High Precision
5 Face Machining
Center

Large Scale
3d Probe

- VTH-1055L3
- VTH-1060L3

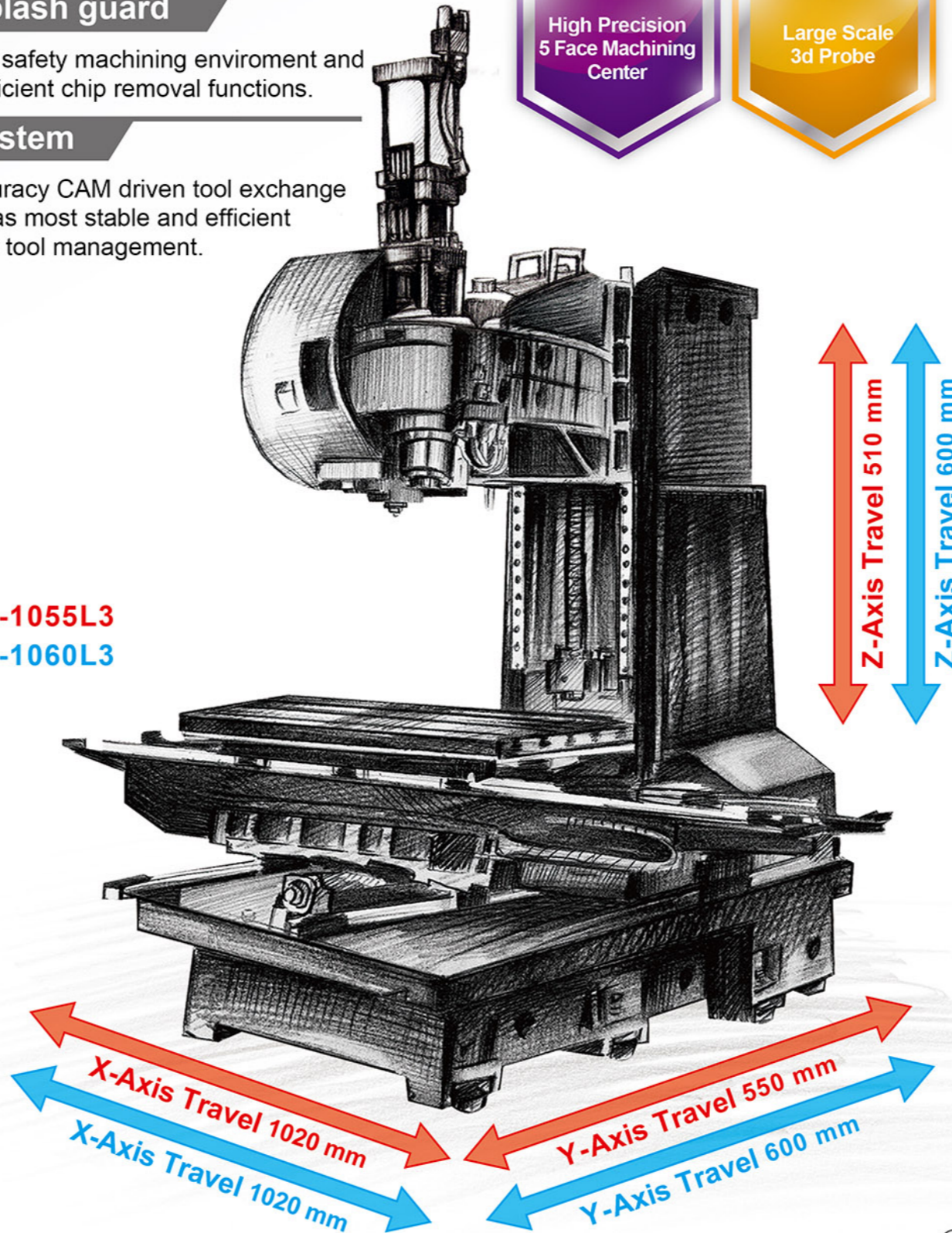

VTH-1055L3

Rapid feed rate : 48000 / 48000 /
32000 mm/min
Travel : 1020 / 550 / 510 mm
Table size : 1200mm x 530mm

VTH-1060L3

Rapid feed rate : 48000 / 48000 /
32000 mm/min
Travel : 1020 / 600 / 600 mm
Table size : 1200mm x 600mm



EX : VTH-1060L3

VTH-1055F

X / Y / Z axis rapid feed rate : 48000 / 48000 / 32000 mm/min
 X / Y / Z axis travel : 900 / 520 / 510 mm
 A axis (tilting) : +30°~-120°
 C axis (rotating) : 360°
 Max.C axis dia. : Ø400mm
 Work table size : Ø320mm



VTH-1055F
Five axis machining center



5 axis

Multi-functional , High-efficiency

High-efficiency, High-Accuracy

Rotary/ Tilting table
 Worm gear transmission

Max. work piece size
 Ø400mm x H300mm
 (Table size Ø320mm)
 Max. Loading: 100kg

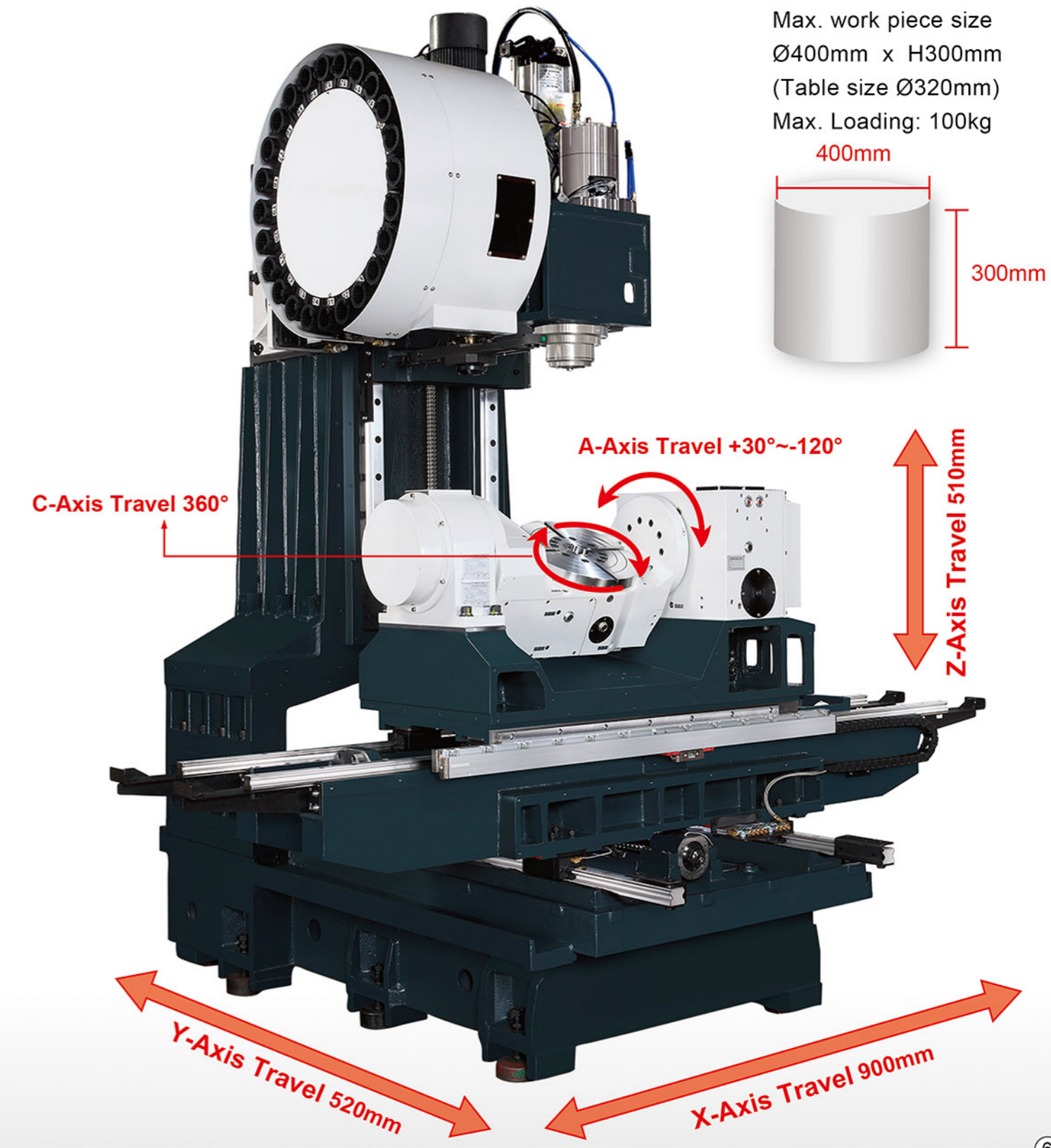

VTH Series

Belt type Spindle

- P4 grade high precision angular contact bearings plus enlarged supporting position design largely increase axial and radial rigidity and cutting ability.
 - Special air-curtain design on spindle nose to prevent coolant / dust getting inside of the spindle.
 - Four pieces of powerful coolant nozzle around spindle nose plus two-hole nozzle aside.
 - New designed of V shape belt to reduce the noise.
- With standard spindle speed 8000 rpm
(opt. 10000 / 12000 rpm)



Spindle Motor Power-Torque diagram

Fanuc

Fanuc β i1 12/10000

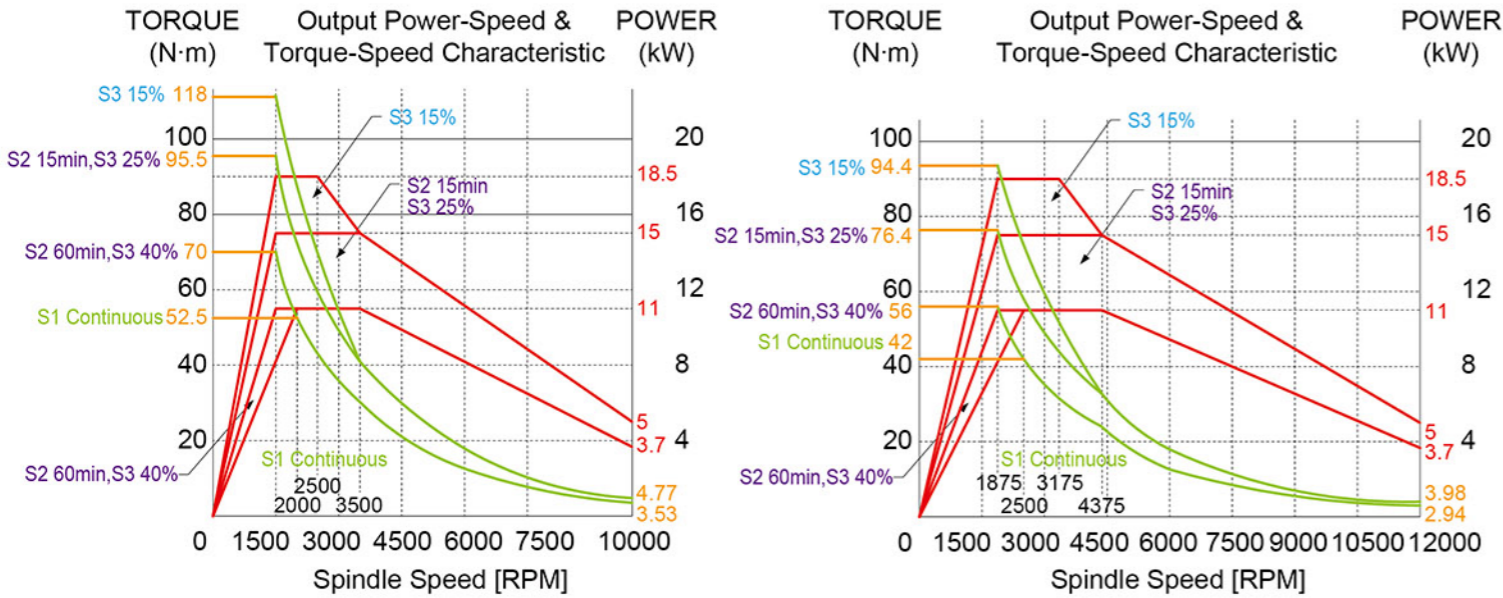

Mitsubishi

Mitsubishi SJ-DG11/100

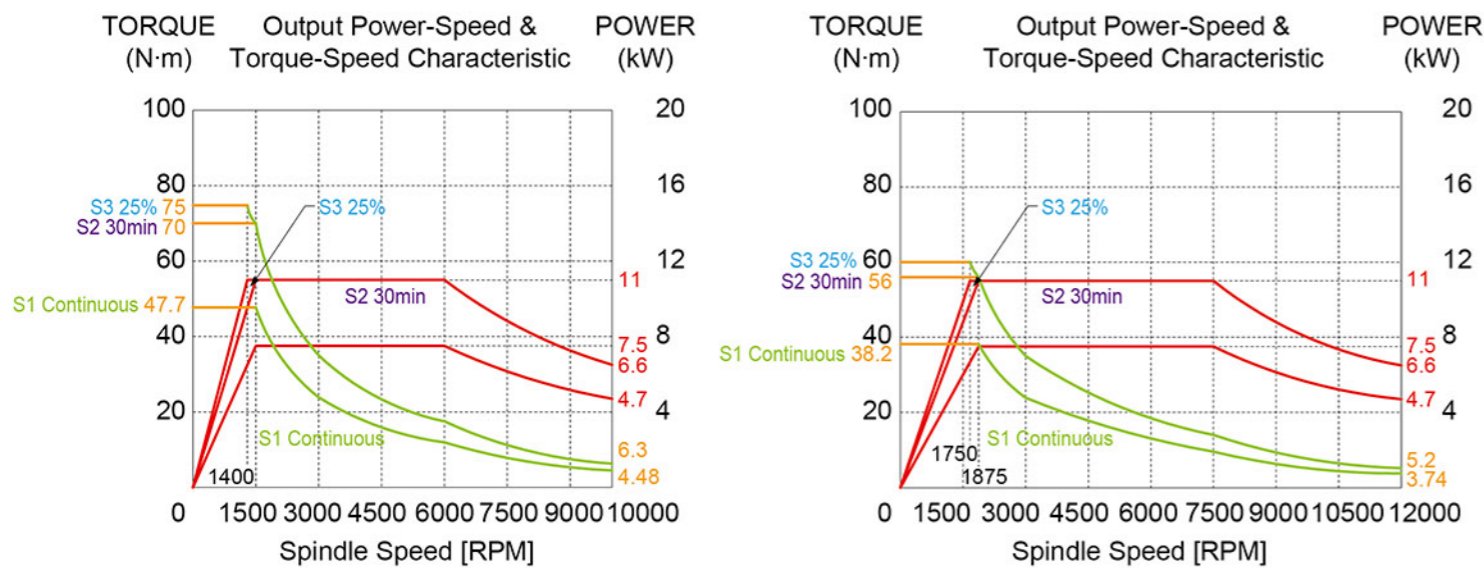

Built-in type Spindle

- Adapt powerful spindle motor, suitable for high dynamic machining with low vibration.
- Standard speed BBT-40 12000 rpm (opt. 15000 rpm)
- Spindle is with air-curtain design. Lubricant with grease.



Spindle Motor Power-Torque diagram

Fanuc

Fanuc β i1 112S/15000

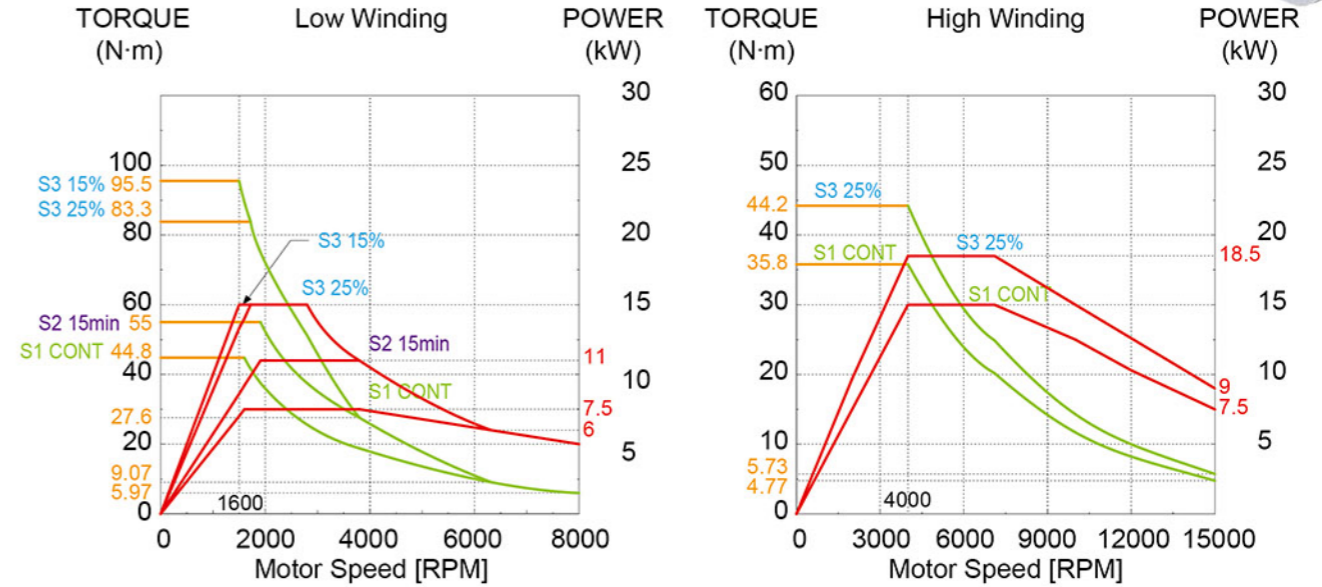

Mitsubishi

Mitsubishi SJ-2B4357TKH

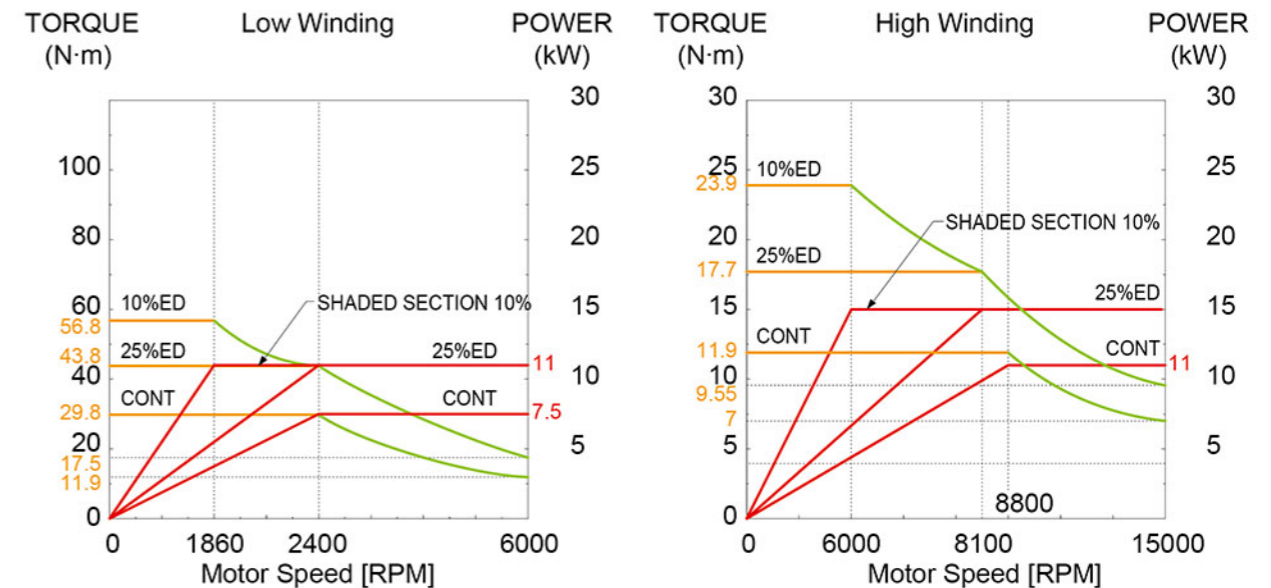

VTH-1055L3/1060L3

Unit:mm

Working table dimension

T-Slot

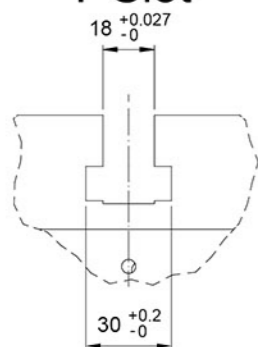

	1055L3	1060L3
A	1200	1200
B	530	600
C	100	125

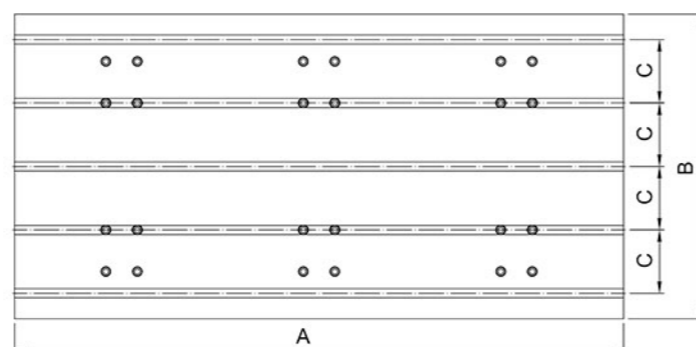

VTH-1055L3/1055F

Machine dimension

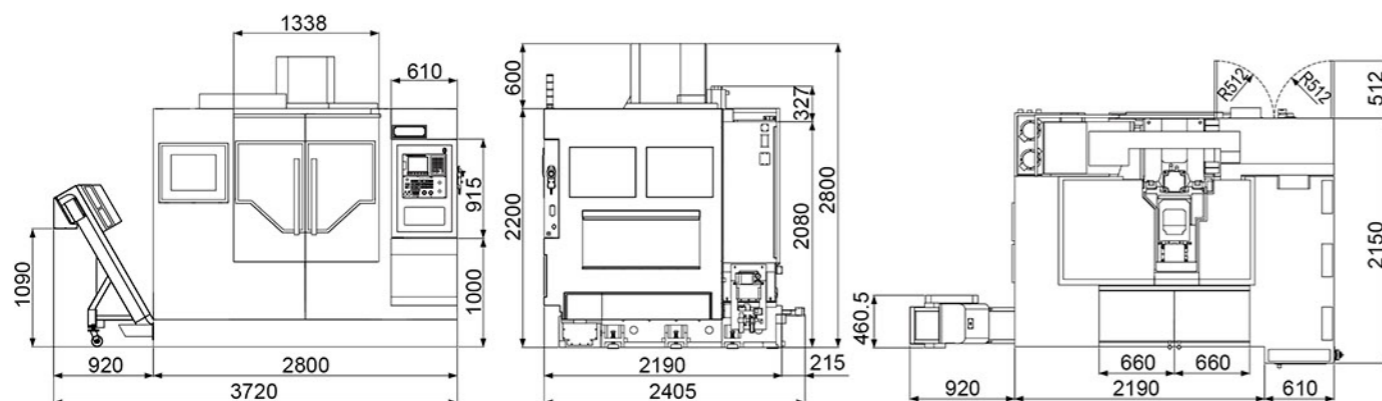

VTH-1060L3

Machine dimension

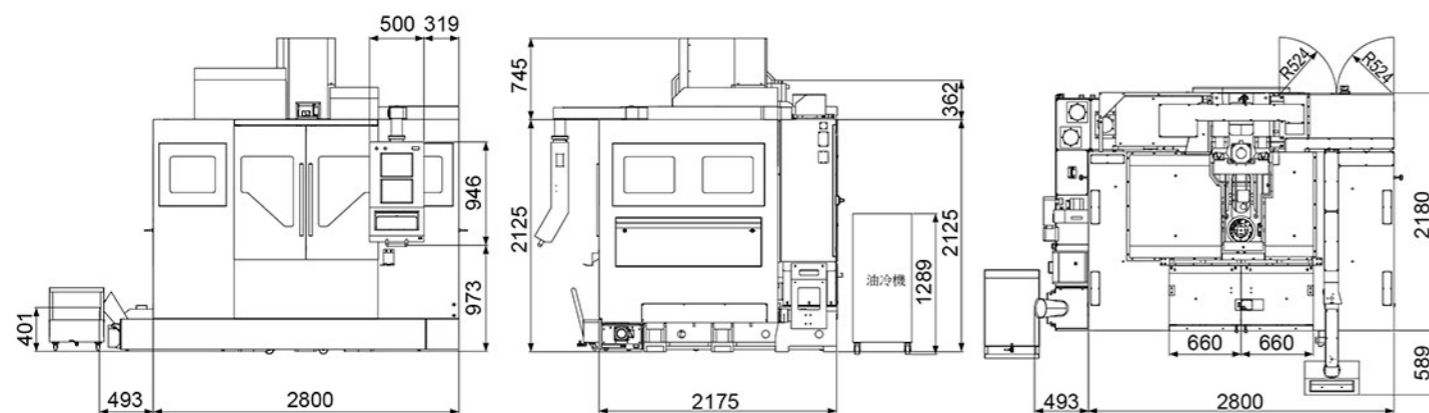

VTH-1055F

Unit:mm

Five axis working area

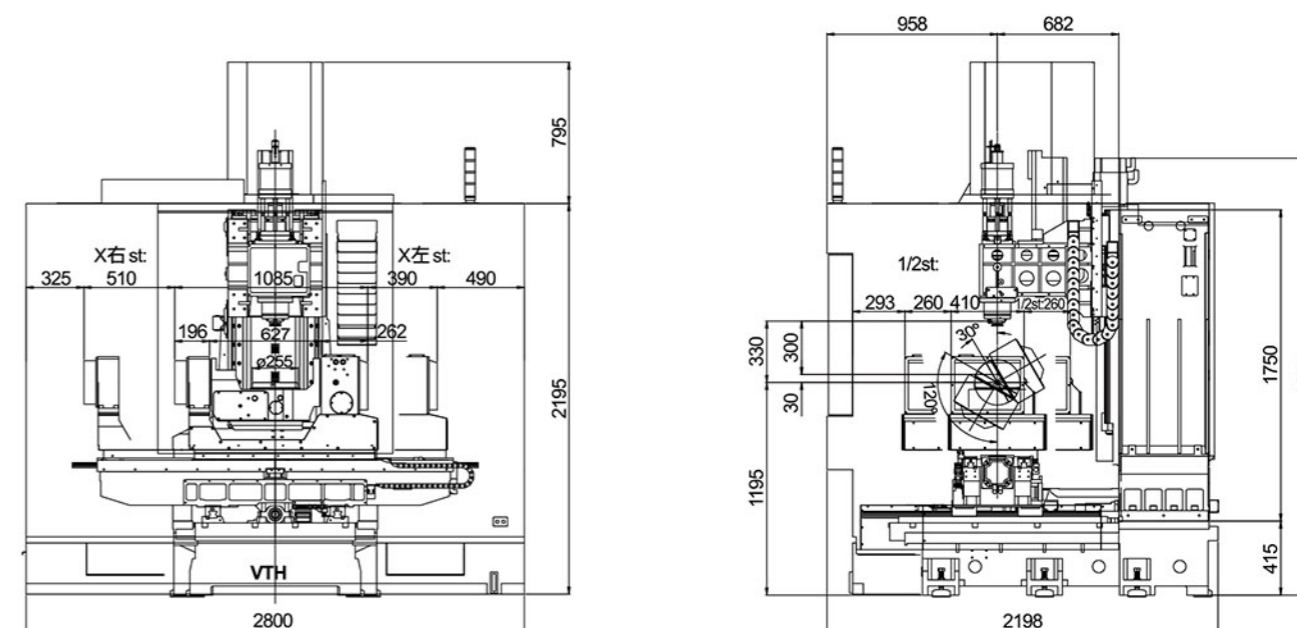

Five axis working example

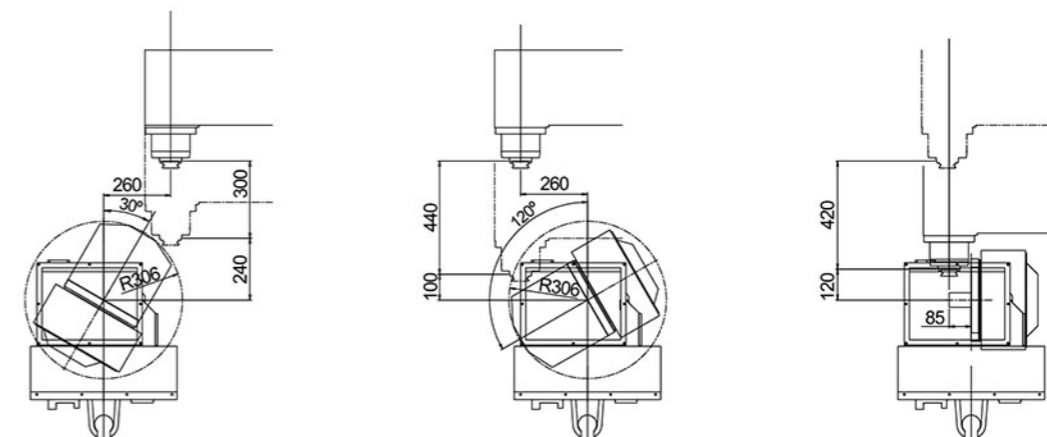
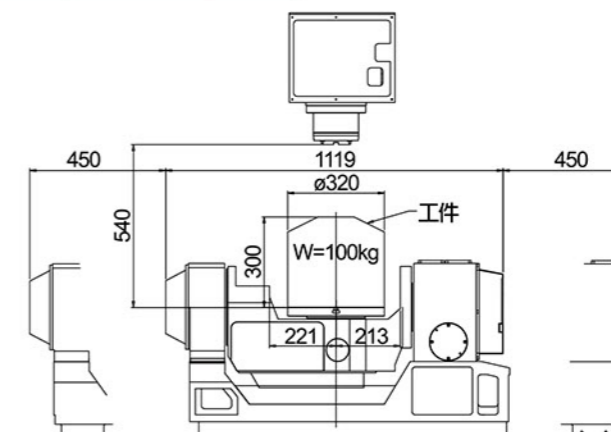

VTH-1055L3/1060L3 3 Axis Specification

Model	VTH-1055L3	VTH-1060L3
Work Table		
Table size	1200 x 530 mm (47.24"x 20.86")	1200 x 600 mm (47.24"x 23.62")
T-slot number / wide / pitch	5 x 18 mm x 100 mm (5 x 0.71" x 3.93")	5 x 18 mm x 125 mm (5 x 0.71" x 4.92")
Max. loading	600 kg (1321 lbs)	
Travel		
X axis	1020 mm (40.1")	
Y axis	550 mm (21.65")	600 mm (23.62")
Z axis	510 mm (20")	
Spindle		
Spindle nose to work table surface	150-660 mm (5.9"-26")	150-750 mm (5.9"-29.53")
Spindle center to column front	585 mm (23")	627 mm (24.69")
Taper	BT40 (opt.CAT40,DIN40)	
Speed	Belt type 8000 rpm	
Front bearing dia.	70 mm (2.8")	
Feed		
Rapid (X / Y / Z)	48000 / 48000 / 32000 mm / min opt.36000 / 36000 / 32000 mm / min	
Cutting	10000 mm / min (394 rpm)	
Z axis counter balance	Without	
Ball screw dia. & pitch	Ø40 mm , P16 / 16 / 12 mm opt.P12 / 12 / 12 mm	
Guide way	Linear guide way W35 / 45 / 45 mm	
Accuracy VDI 3441(JIS B6338)		
Positioning	P 0.014 mm (±0.004 / 300 mm)	
Repeatibility	PS 0.010 mm (±0.003 mm)	
ATC System		
Taper	BT 40	
Tool capacity	24T	
Tool exchange time	T-T 1.8 sec, C-C 3.8 sec	
Max. tool dia. (w/ adjacent tool)	75 mm (2.95")	
Max. tool dia. (w/o adjacent tool)	125 mm (4.92")	
Max. tool length	300 mm (11.81")	
Max. tool weight	7 kg, 120 kg (17.6 lbs, 264.2lbs)	
General		
Power required	25 kVA	
Air pressure required	6 kg / cm ² , 200 L / min	
Machine dimension (W x D x H)	2800 x 2405 x 2800 mm (110.2" x 94.6" x 110.2")	3370 x 2765 x 2870 mm (132.7" x 108.9" x 113.0")
Machine weight	6500 kg (14317lbs)	7000 kg (15414lbs)

■ Both specifications & design characteristics are subject to change without prior notice.

Standard Features

- 24 tool arm-type ATC system
- Coolant system
- Fully enclosed splash guard
- Work lamp
- Auto. lubrication system
- Indicating light
- Spindle air blast function
- Sides and rear chip flush system
- Cutting air blast function
- Spindle air curtain system
- Rigid tapping
- Heat exchanger for electrical cabinet
- Tool box and adjusting tools
- Leveling bolts and pads
- Spindle oil cooler
- Operational / controller / maintenance manuals
- Air gun
- Coolant gun

Optional features

- Belt type Spindle 10000 / 12000 rpm
- Direct driven Spindle 12000 rpm
- Built-in type Spindle 12000 / 15000 rpm
- 30 tool arm-type ATC system
- 32 tool arm-type ATC system
- X / Y / Z axis roller type linear guide way
- 4th axis system interface ready (pre-wired only)
- 4th axis system
- Auto. tool length measuring system
- CTS (Coolant Through Spindle) system
- Y direction dule screw type chip conveyor
- Chain type chip conveyor
- Axis optical scale system
- Oil skimmer
- Transformer

VTH-1055F 5 Axis Specification

Model	VTH-1055F
Travel	
X Axis	900 mm (35.43")
Y Axis	520 mm (20.47")
Z Axis	510 mm (20")
A Axis (tilting)	+ 30° ~ -120°
C Axis (rotating)	360°
Max. C axis dia.	Ø400 mm
Max. A axis speed	25 rpm
Max. C axis speed	25 rpm
Work table size	Ø320 mm
T-slot size	12 mm
Max. loading	100 kg (220.2 lbs)
Spindle	
Spindle nose to work table surface	30-540 mm (1.19"-21.25")
Spindle center to column front	958 mm (37.71")
Taper	BT40 (opt.CAT40,DIN40)
Speed	Belt type 8000 rpm
Front bearings dia.	70 mm (2.8")
Feed	
X / Y / Z rapid feed rate	48000 / 48000 / 32000 mm / min opt.36000 / 36000 / 32000 mm / min
X / Y / Z cutting feed rate	10000 mm / min (394 rpm)
Z axis counter balance	Without
Ball screw dia. & pitch	Ø40 mm , P16 / 16 / 12 mm opt.P12 / 12 / 12 mm
Guide way	Linear guide way W35 / 45 / 45 mm
Accuracy VDI 3441(JIS B6338)	
X / Y / Z axis positioning	P0.014 mm (±0.004 / 300 mm)
X / Y / Z axis repeatability	PS0.010 mm (±0.003 mm)
C axis positioning	20"
A axis positioning	20"
C axis repeatability	6"
A axis repeatability	4"
ATC System	
Taper	BT 40
Tool capacity	24T
Tool change time	T-T 1.8 sec , C-C 3.8 sec
Max. tool dia. (w/ adjacent tool)	75 mm (2.95")
Max. tool dia. (w/o adjacent tool)	125 mm (4.92")
Max. tool length	300 mm (11.81")
Max. tool weight	7 kg, 120 kg (17.6 lbs, 264.2lbs)
General	
Power required	25 kVA
Air pressure required	6 kg / cm ² , 200 L / min
Machine dimension (W x D x H)	2800 x 2405 x 2800 mm (110.2" x 94.6" x 110.2")
Machine weight	6650 kg (14647 lbs)

■ Both specifications & design characteristics are subject to change without prior notice.

Standard Features

- 24 tool arm-type ATC system
- Coolant system
- Fully enclosed splash guard
- Work lamp
- Auto. lubrication system
- Indicating light
- Spindle air blast function
- Sides and rear chip flush system
- Cutting air blast function
- Spindle air curtain system
- Rigid tapping
- Heat exchanger for electrical cabinet
- Tool box and adjusting tools
- Leveling bolts and pads
- Spindle oil cooler
- Operational / controller / maintenance manuals
- A-axis angular encoder system
- Air gun
- Coolant gun

Optional features

- Belt type Spindle 10000 / 12000 rpm
- Direct driven Spindle 12000 rpm
- Built-in type Spindle 12000 / 15000 rpm
- 30 tool arm-type ATC system
- 32 tool arm-type ATC system
- X / Y / Z axis roller type linear guide way
- Auto. tool length measuring system
- CTS (Coolant Through Spindle) system
- Y direction dule screw type chip conveyor
- Chain type chip conveyor
- Axis optical scale system
- Oil skimmer
- Transformer