

High Efficiency Machining Center



## VE Series

V-22iF(iR)/V-30iF(iR)  
V-32iF(iR)/V-32AF(AR)  
V-42iF(iR)/V-42AF(AR)  
V-52AF(AR)

**LEADWELL**  
LEADWELL CNC MACHINES MFG., CORP.



**LEADWELL CNC MACHINES MFG., CORP.**



No. 23 Gong 33th Road, Taichung Industrial Park  
Taichung 407, Taiwan  
T: 886 - 4 - 23591880  
F: 886 - 4 - 23592555, 886 - 4 - 23593875  
E: sales@leadwell.com.tw

[www.leadwell.com.tw](http://www.leadwell.com.tw)

\* All performance are based on 220V/3PH/60HZ. Specifications are subject to change without notice.

2017.05



# VERTICAL MACHINING CENTERS

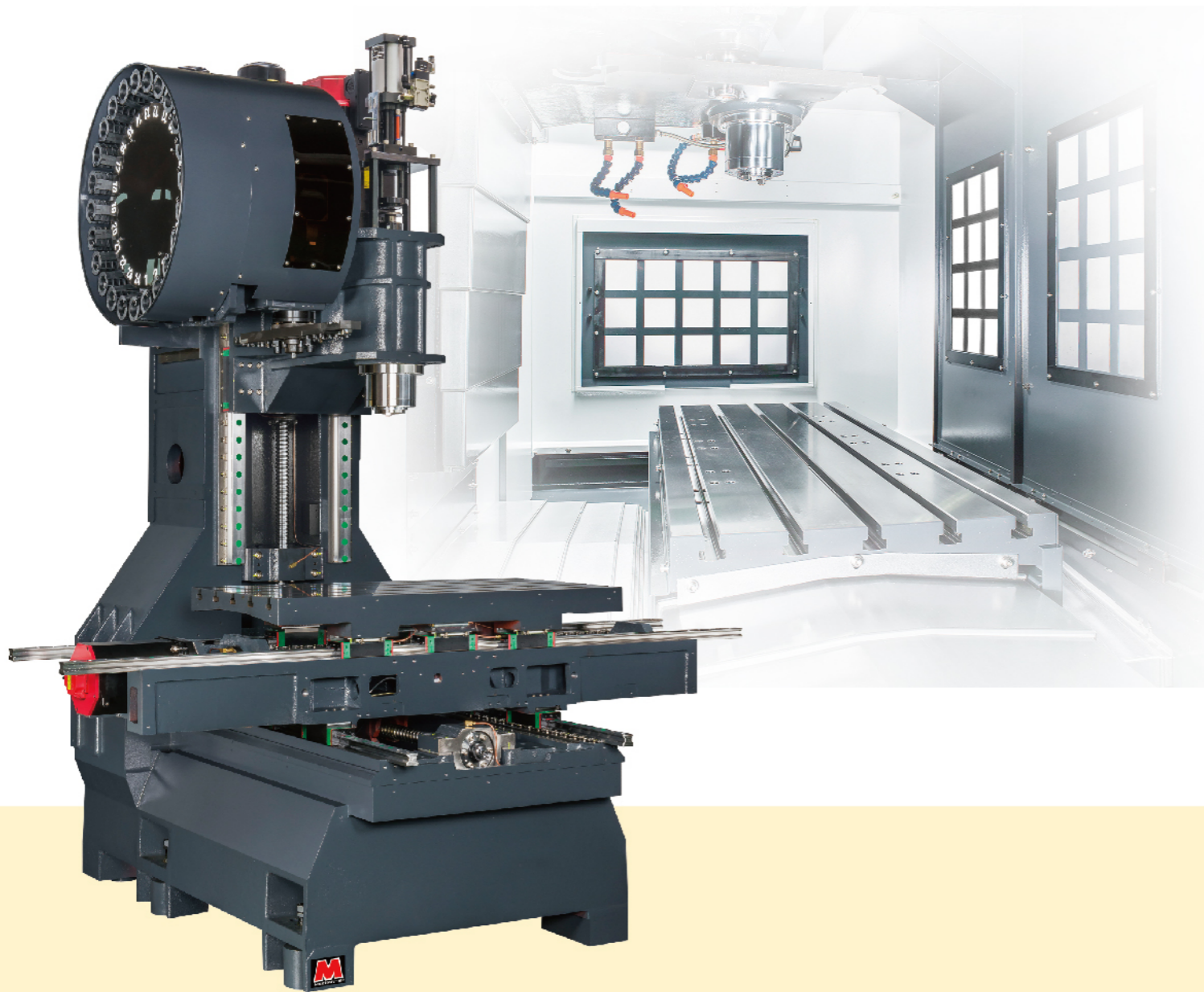

## High Efficiency Machining Center

### High Rigidity:

- FEA Analysis
- High rigidity structure design
- 3 Axis ball screw prestressing

### High Reliability:

- Roller type motion system
- 3 Axis absolute motor

### High Efficiency:

- V-32A.V-42A.V-52A with high torque spindle motor
- Rapid feed rate 48/48/36 mm
- Spindle speed 12,000 rpm(optional)
- Tool change time T to T 1.8 sec
- Tool change time C to C 4 sec

### High Flexibility:

- 30 tools magazine available
- 4/5 axis rotary table available
- Front/Rear Chip Disposal available

# FEA REPORT(Finite Element Analysis)

### Optimum

- Section areas
- Moments of inertia
- Torsional constant
- Plate thickness
- Bending stiffness
- Transverse shear
- Vibration reduce

### With FEA you can:

1. Predict and improve product performance and reliability.
2. Reduce physical prototyping and testing .
3. Evaluate different designs and materials .
4. Optimize designs .

V-22 SERIES

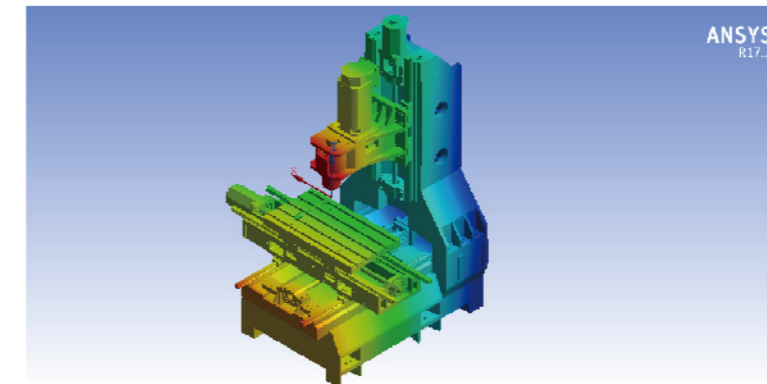
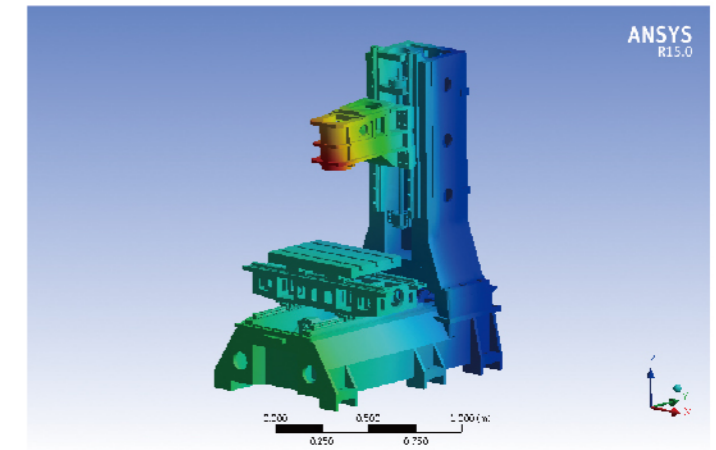

V-32 SERIES

V-42 SERIES

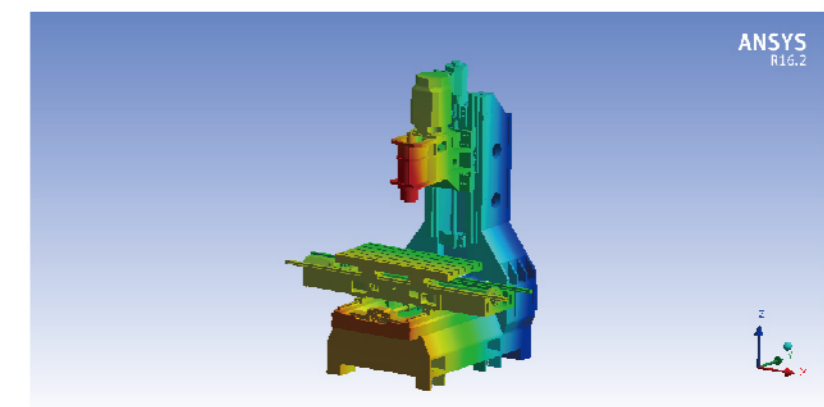



# PERFORMANCE

## V-42iF/iR

**FACE MILL**

Removal Rate **260cc/min.**

Tool Ø63mm  
Spindle Speed 1500rpm  
Feed Rate 1300mm/min  
Width of Cut 50mm  
Depth of Cut 4mm

**END-DRILL**

Removal Rate **144cc/min.**

Tool Ø20mm  
Spindle Speed 2800rpm  
Feed Rate 900mm/min  
Width of Cut 20mm  
Depth of Cut 8mm

**U-DRILL**

Drilling **Ø42mm**

Tool Ø42mm  
Spindle Speed 1500rpm  
Feed Rate 130mm/min.  
Depth of Cut 50mm

**TAP**

Tapping **M16**

Spindle Speed 350rpm  
Feed Rate 700mm/min.

**RIGID TAP**

Tapping **M20**

Spindle Speed 1500rpm  
Feed Rate 3750mm/min.

**MATERIAL**

**S45C**

# NASA REPORT

TEST REPORT		YEAR						
		10	2					
ITEM	NASA TEXT	MODEL	V-42i					
TEST CONDITION	Material: Aluminum #6061 Rough Machining: Tool: Ø12 End Mill Speed: 8000RPM Feedrate: 3000mm/min	Finish Machining: Tool: Ø12 End Mill Speed: 8000RPM Feed rate: 2000mm/min	NUMBER: #011					
			DATE: 2013/5/18					
TEST RESULT		PERSONNEL	Thomas					
		Tolerance	Side	Measured	Tolerance	Side	Measured	
	H	0.015/300	A\B	*	⊥	0.015/140	d\A	0.002/140
	//	0.015/140	a\c	0.006/140	∠	17.7	i\k	17.7019
	//	0.015/140	b\c	0.003/140	∠	13.2	m\n	13.2743
	//	0.015/200	g\c	0.002/200	—	0.015/200	abcd	0.001
	//	0.015/200	f\h	0.007/200	—	0.015/200	efgh	0.001
	⊥	0.015/200	g\c	0.002/200	○	0.005	C	0.014
	⊥	0.015/200	f\c	0.001/200	Ra	2	abcd	△△△3.2
	⊥	0.015/200	e\h	0.001/200	Ra	2	A\B	△△△3.2
	⊥	0.015/200	h\g	0.002/200	L	141.42mm	A\C	140.217
	⊥	0.015/140	a\c	0.001/140	L	141.42mm	D\B	140.221
⊥	0.015/140	b\c	0.006/140	L	200. mm	E\G	198.794	
⊥	0.015/140	c\c	0.003/140	L	200. mm	F\H	198.801	

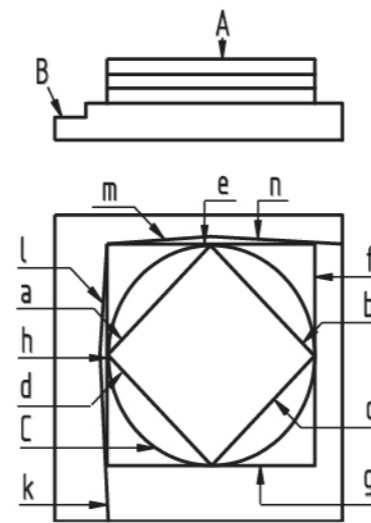

# SPINDLE POWER CURVE

- Continuous N-m
- 30 min N-m
- Continuous KW
- 30 min KW

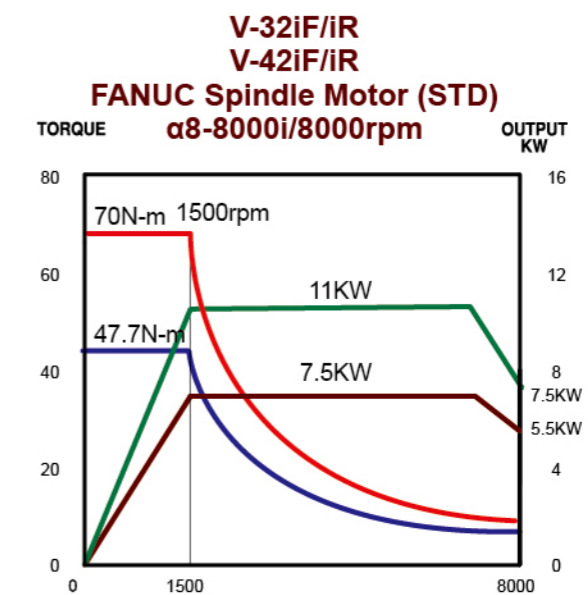
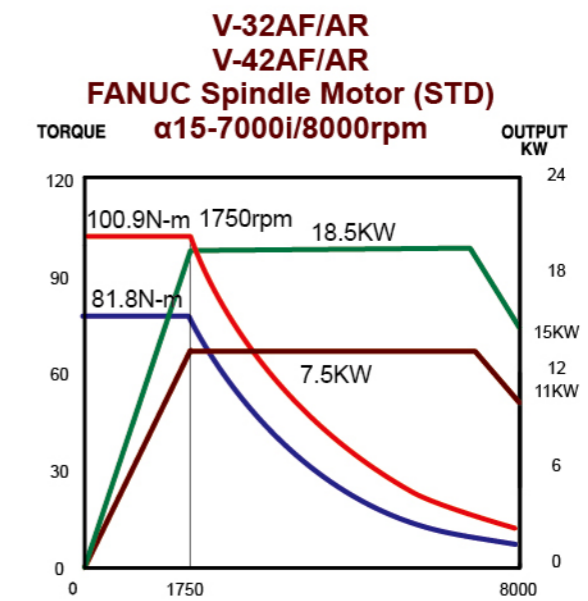
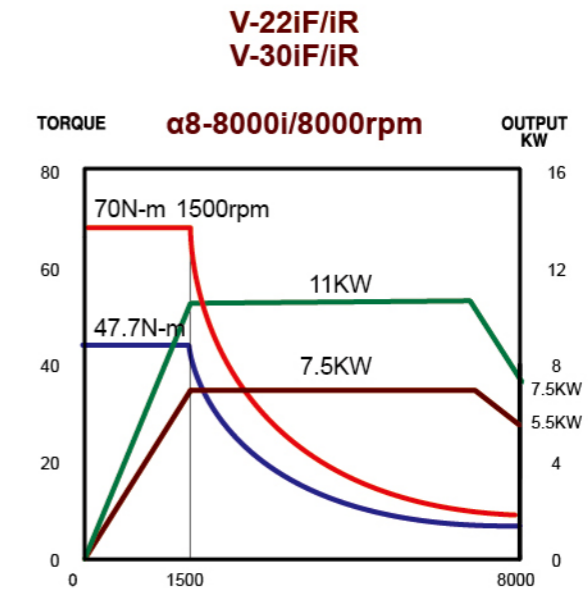

# SPINDLE POWER CURVE

- Continuous N-m
- 30 min N-m
- Continuous KW
- 30 min KW

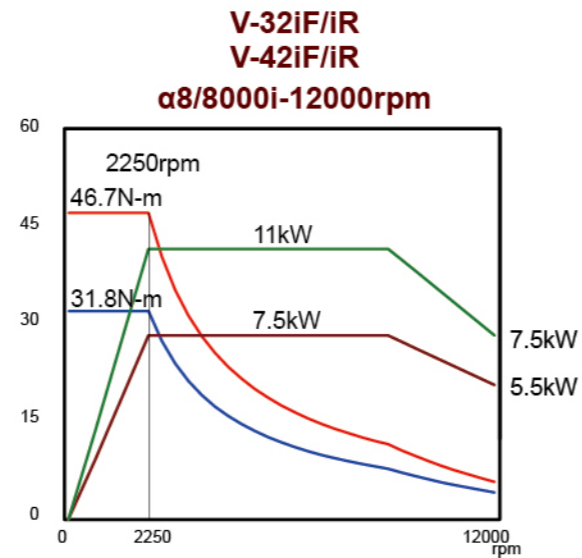
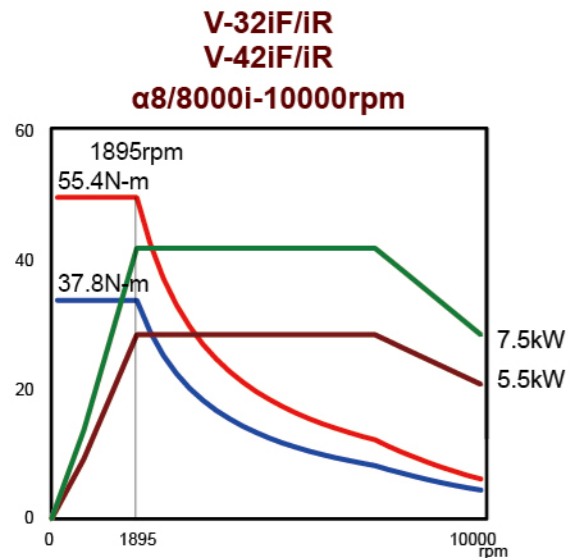
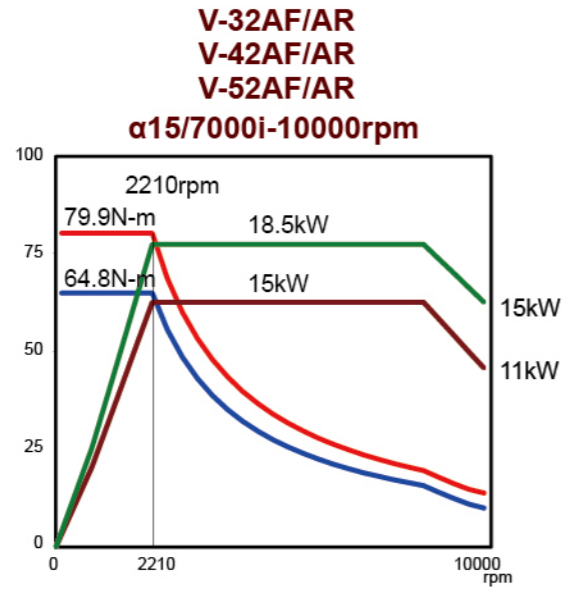
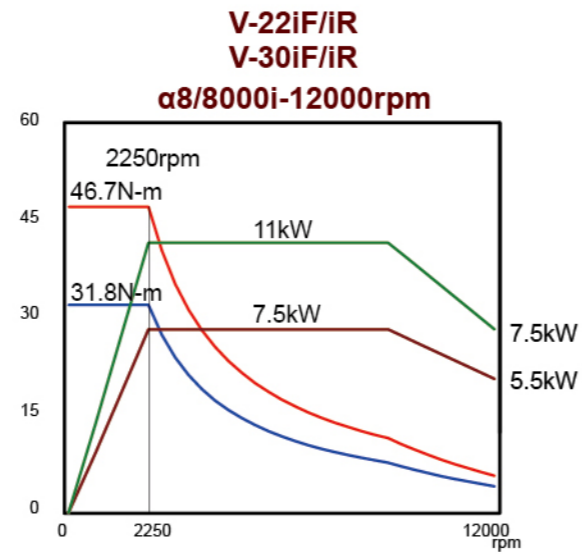
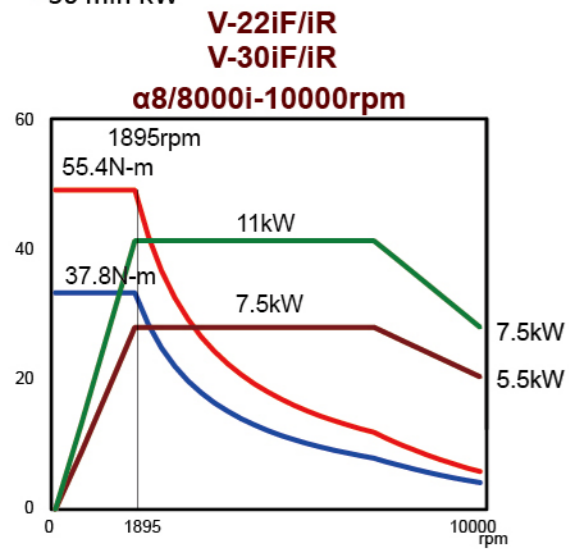

# INTERNAL DIMENSION

## Table Size

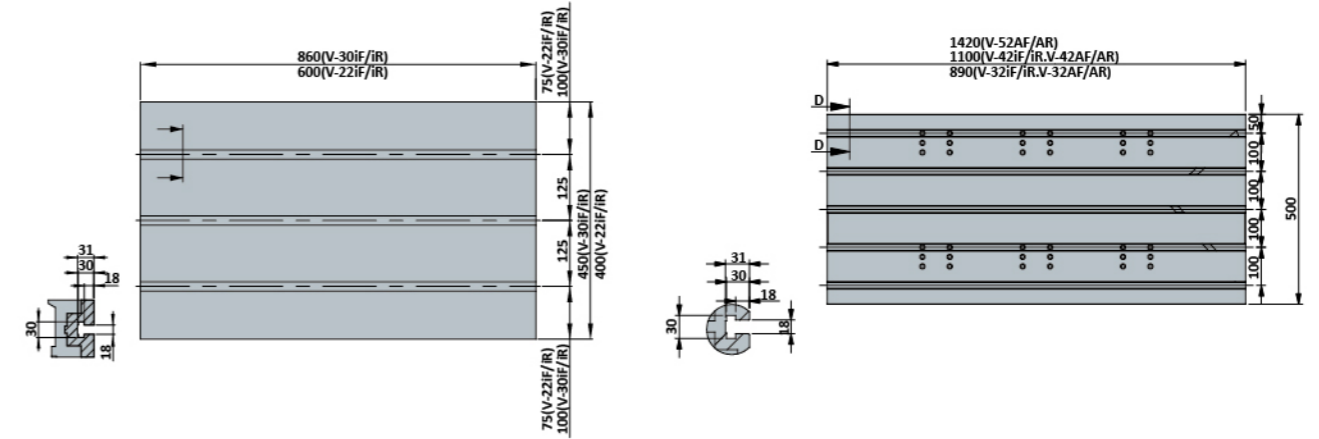

## Travel Drawing

### V-22i/V-30i (FRONT)

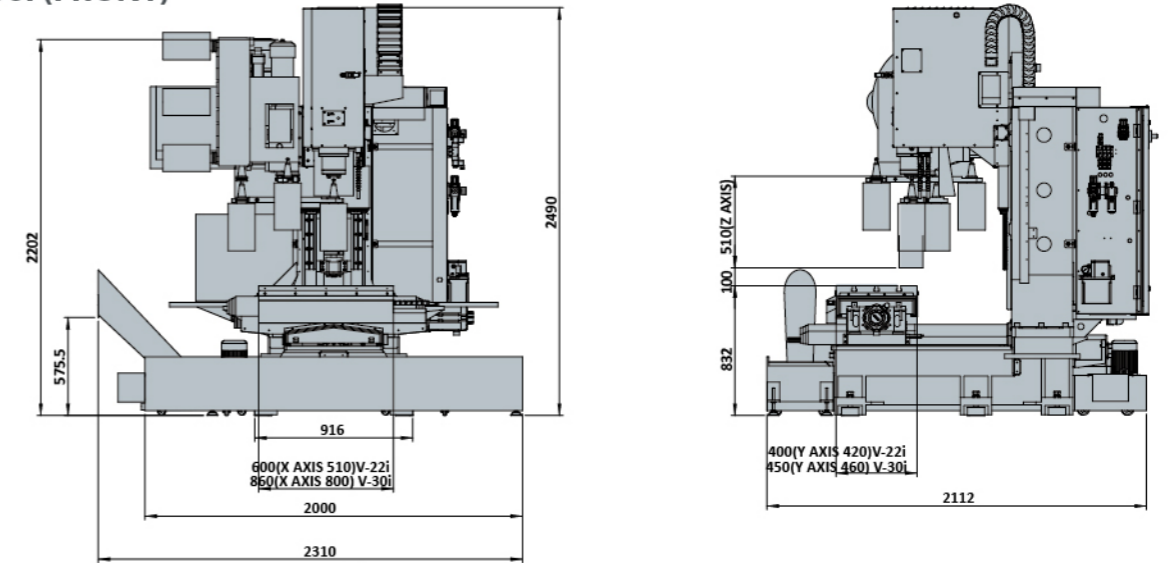

### V-32i/V-42i(REAR) V-32A/V-42A(REAR) V-52A(REAR)

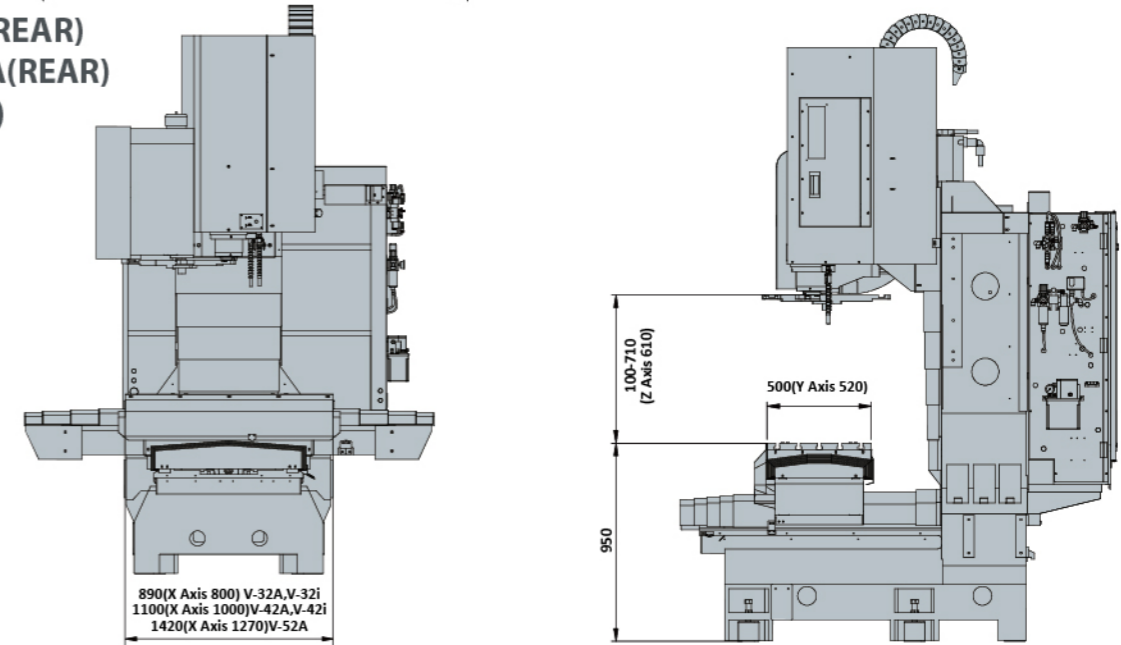



# OUTLINE DIMENSION

V-22iF/V-30iF

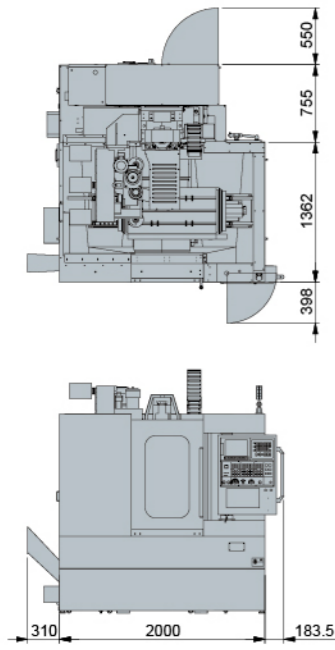

V-22iR/V-30iR

unit: mm

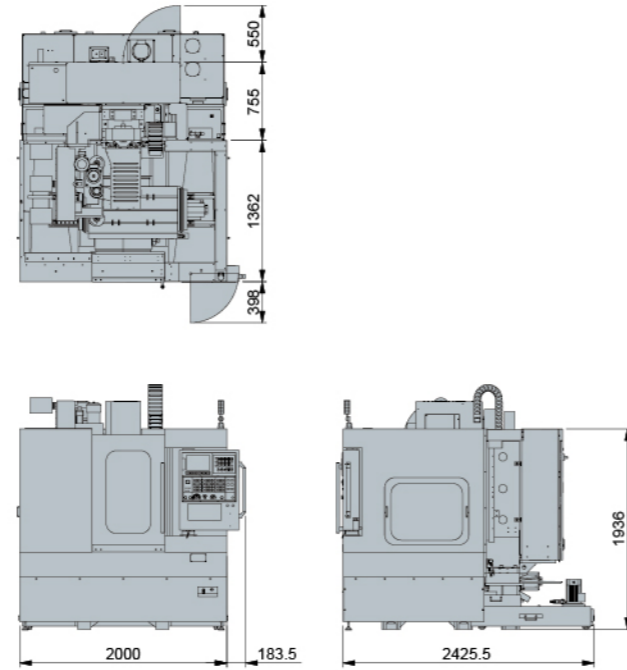

V-32iR/V-32AR

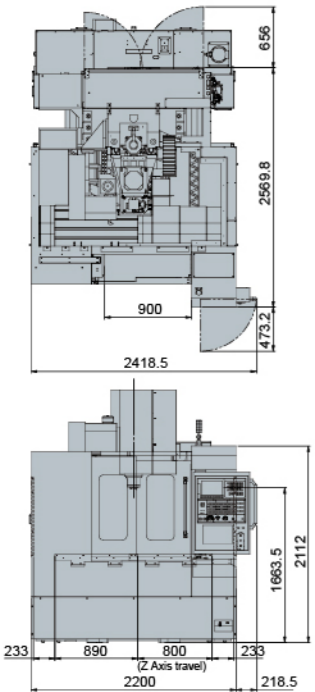

V-32iF/V-32AF

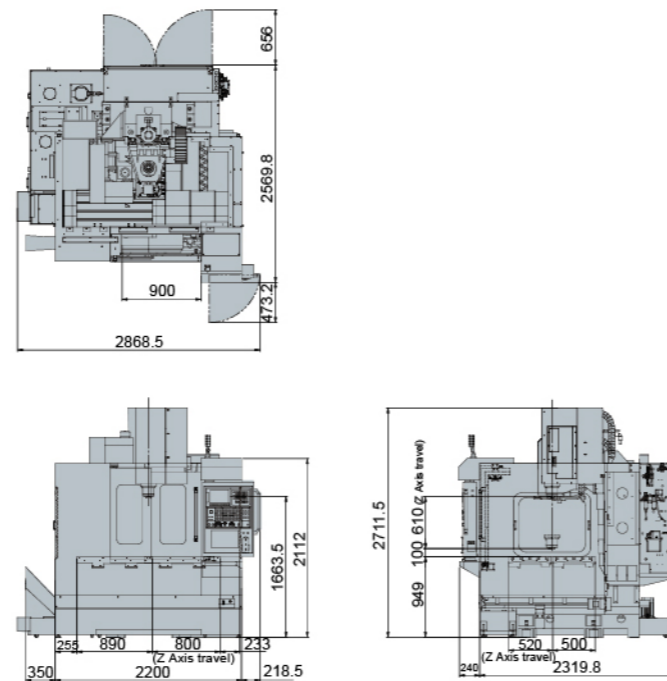

# OUTLINE DIMENSION

V-42iR /V-42AR

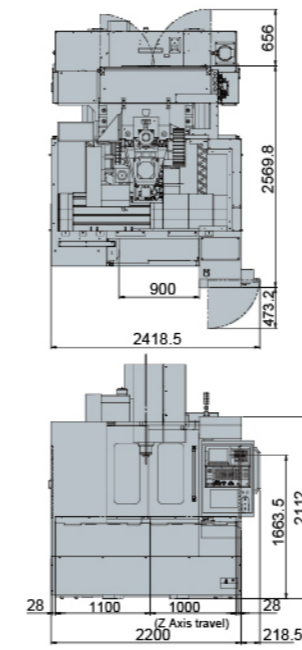

V-42iF/V-42AF

unit: mm

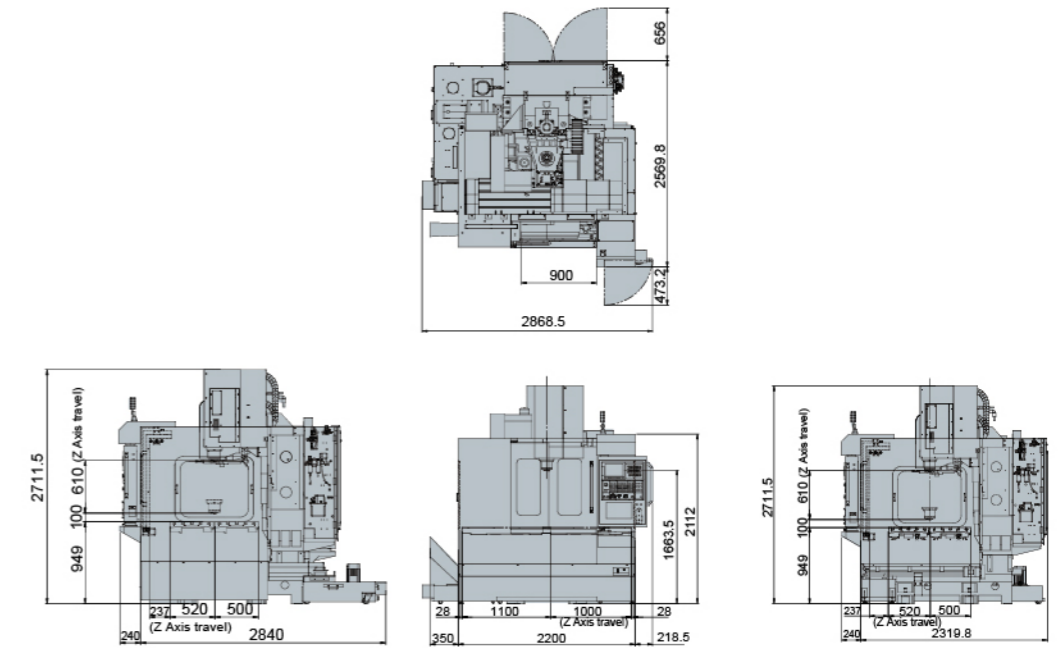

V-52AF

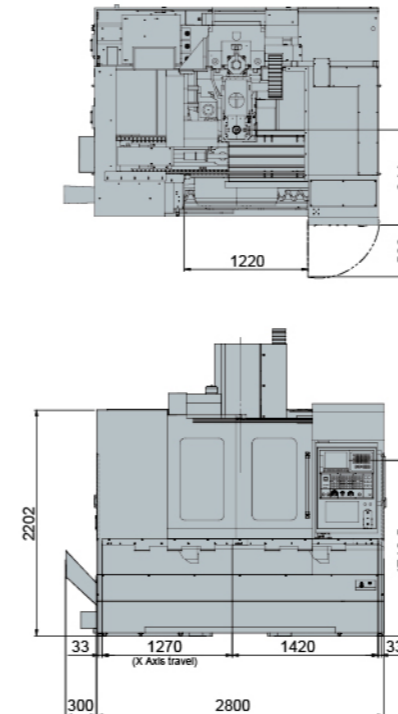

V-52AR

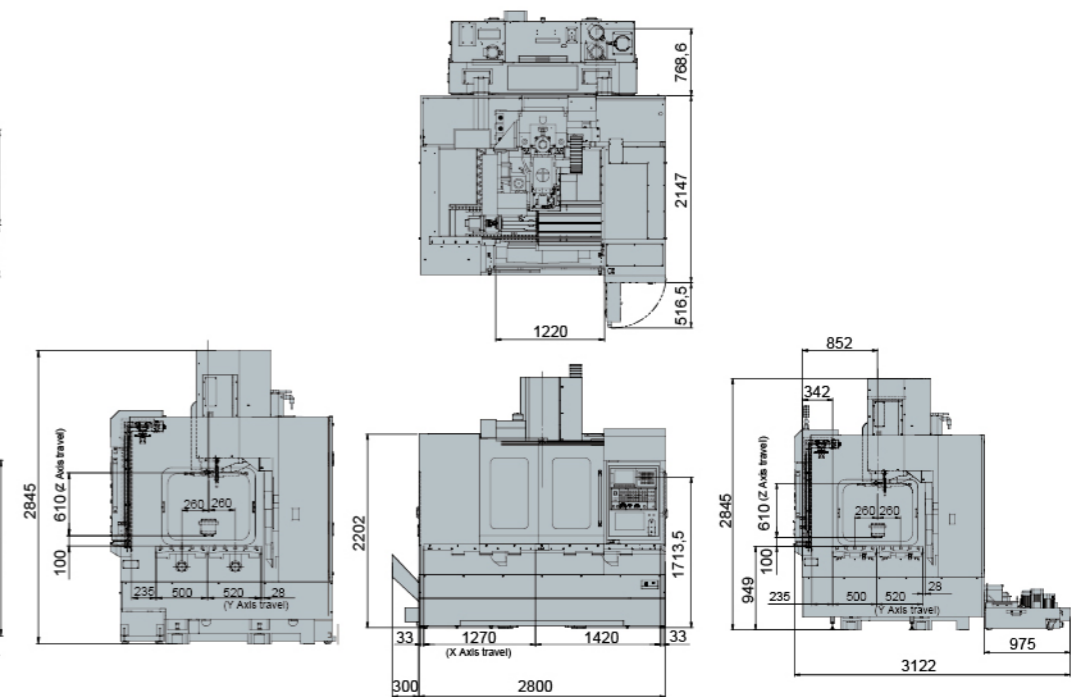

# VERTICAL MACHINING CENTERS

## Pull Stud

Standard

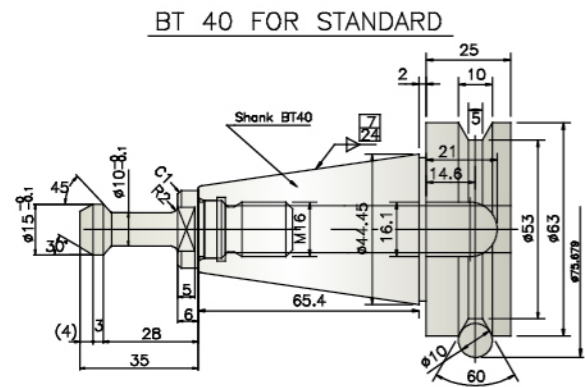

Optional

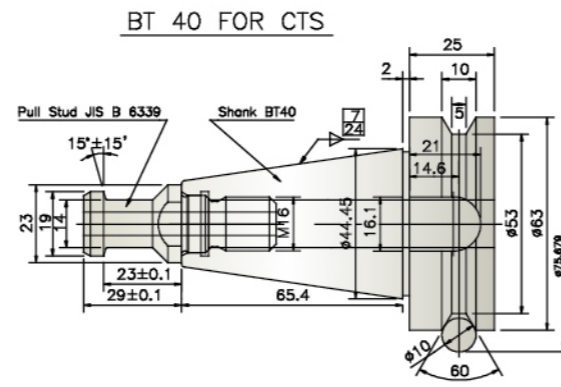

Optional

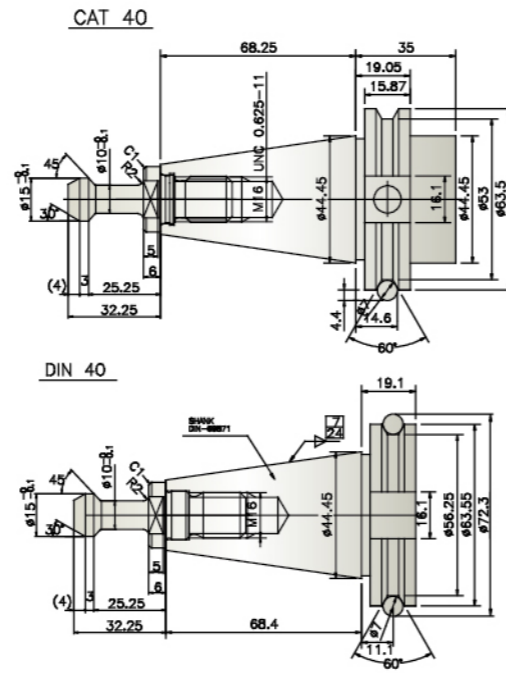
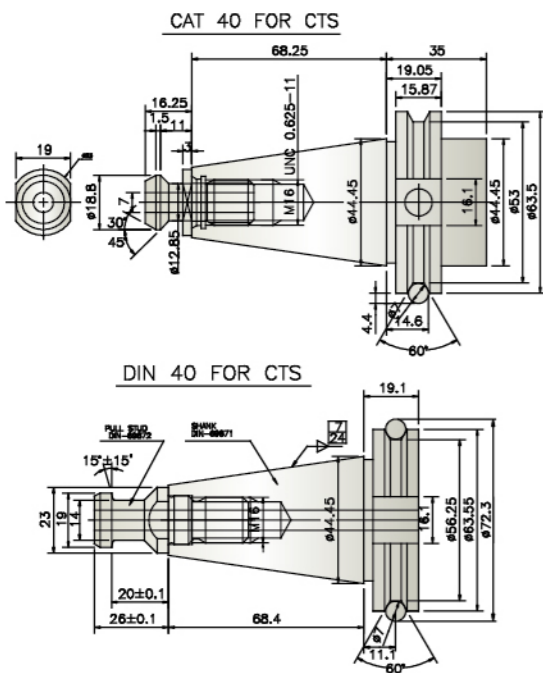

## Cartridge Type Spindle



## BBT Two face contact

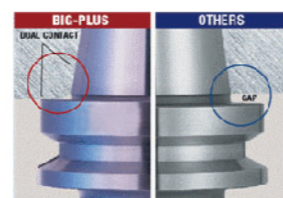

# HIGH PERFORMANCE ROTARY TABLE

## LEADWELL®

### LWAR Series (Air Brake) LWHR Series (Hydraulic Brake)

LWAR-210/250  
LWHR-210/255/320

● Recommend HR Series to use  
**made-in-Japan** dual-lead worm  
and worm gear

Larger Through Hole → Bigger Bearing  
Bigger Bearing → Higher Rigidity



Large diameter



LWAR-210R

### Devised by German

Specialized for Rotary Table, the Radial & Axial bearing can fully support heavy-duty cutting in both radial and axial directions.



LWHR-255R

(Sheet Metal Cover for Both Vertical and Horizontal Applications)



### Made in Japan(opt)

Unique high tensile brass  
Wear life is 2.6 times longer than aluminum bronze PBC3.

### 4th Ratable Suggest Table

Model	Air			Hydraulic	
V-22iF/iR	LWAR-125R	LWAR-170R	LWAR-210R		
V-30iF/iR	LWAR-170R	LWAR-210R	LWAR-250R	LWHR-210R	
V-32iF/iR/AF/AR	LWAR-210R	LWAR-250R		LWHR-210R	LWHR-255N
V-42iF/iR/AF/AR	LWAR-210R	LWAR-250R		LWHR-210R	LWHR-255N
V-52AF/AR	LWAR-210R	LWAR-250R		LWHR-210R	LWHR-255N



# LEADWELL SMART PROCESSOR

## More than a machine

Leadwell is never simply about building a machine and to launch onto the market. Our years of experience, we learn that the right programs must be developed to ensure the competitiveness of the users.

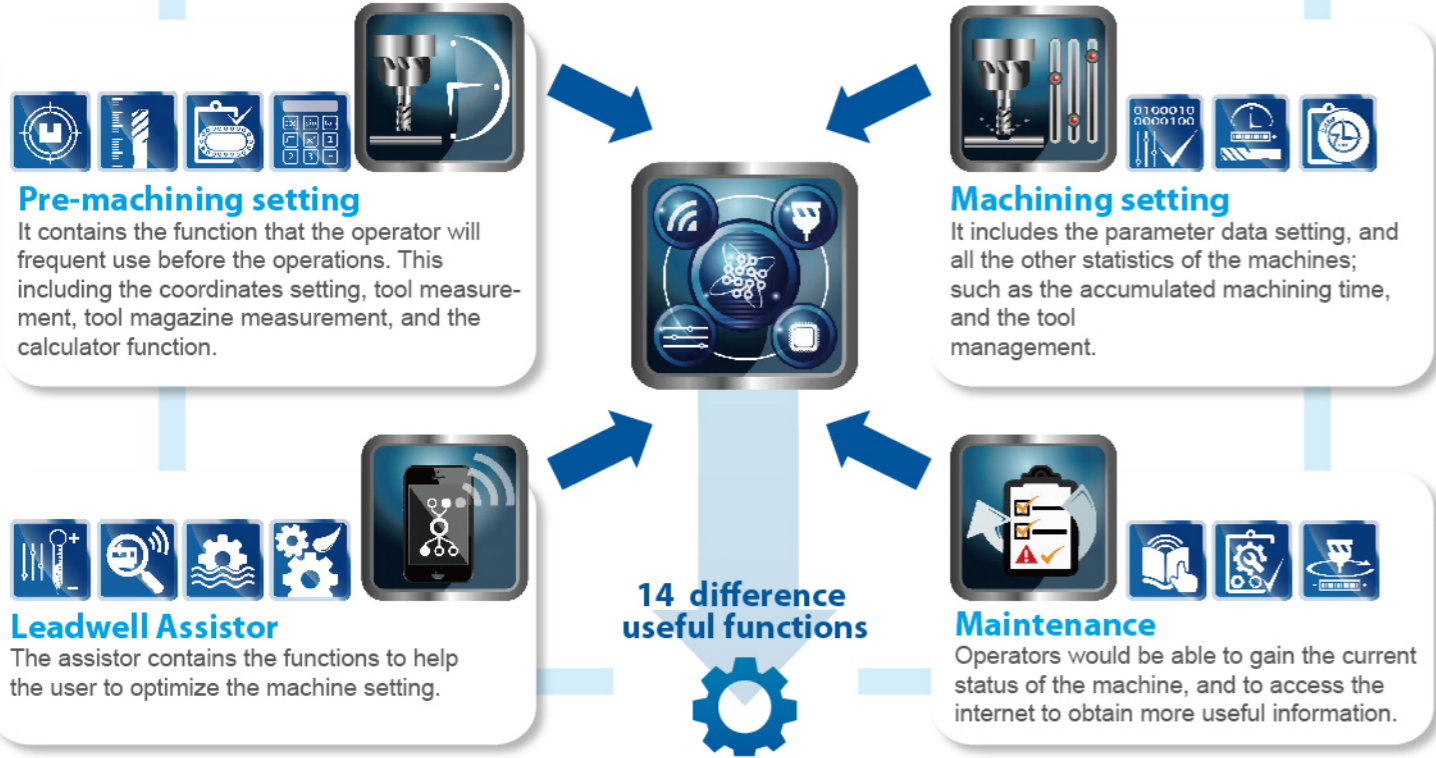

## Machined work pieces.

Users' full satisfaction have always been Leadwell's main focus.

# COOLANT AND CHIP SEPERATION SYSTEM

Rear Chip Disposal

Front Chip Disposal

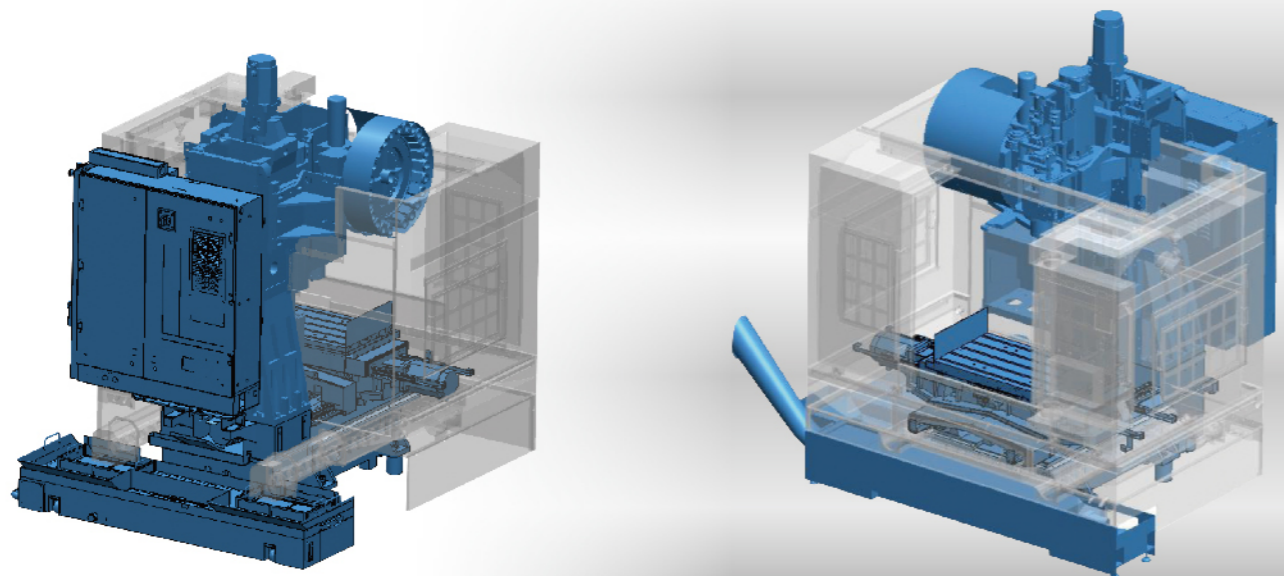

# MACHINE SPECIFICATIONS

ITEM	MODEL	V-22iF/iR	V-30iF/iR	V-32iF/iR	V-32AF/AR
A.T.C	Type	Arm	Arm	Arm	Arm
CAPACITY	Unit				
X axis travel	mm (in)	510(20.1)	800(31.4)	800(31.5)	
Y axis travel	mm (in)	420(16.5)	460(18.1)	520(20.5)	
Z axis travel	mm (in)	510(20.1)	510(20.1)	610(24)	610(24)
Distance from table top to spindle end	mm (in)	100-610(4-24)			100-710(4-28)
Distance from column front to spindle center	mm (in)	460(18.1)	510(20.1)	567(21.5)	
<b>TABLE</b>					
Table size (L x W)	mm (in)	600x400(23.6x15.7)	860x450(33.8x17.7)	890x500(35x19.7)	
Max. table load weight	kg	250	300	500	
T-slot size	mm	18Tx125x3			18Tx100x5
<b>SPINDLE</b>					
Spindle speed	rpm	10000,12000			
Spindle nose (normal size, No.)		7/24 Taper, No.40			
Spindle bearing inner diameter	mm(in)	60(2.36)			70(2.76)
<b>FEED RATE</b>					
Rapid traverse X/Y/Z	m/min(ipm)	48/48/36(1890/1890/1417)			48/48/36(1890/1890/1417)
Max. cutting feed rate	m/min(ipm)	10(394)			
<b>A.T.C.</b>					
Tool storage capacity	pcs	24	24	24	24
Max. tool diameter(with adjacent tools)	mm(in)	80(3.15)	80(3.15)	80(3.15)	80(3.15)
Max. tool length	mm(in)	250(9.8)			250(9.8)
Tool change time T-T/C-C	sec	2.4 / 5			1.8 / 4
<b>MOTORS</b>					
Spindle motor(30 min) FANUC	kw(hp)	11(14.7)			18.5(24.8)
X/Y/Z axis motor	kw(hp)	1.6/3/3(2.1/4/4)			4/4/4(5.4/5.4/5.4)
<b>MACHINE SIZE</b>					
Height of machine (H)	mm(in)	2370(93)			2730(107)
Floor space (L x W)	mm(in)	2440x2117(96x83)FRONT/2130x2400(84x94)REAR			2870x2560(113x101)FRONT/2440x3010(96x118.5)REAR
Total machine weight	kg	3455 FRONT/3380 REAR	3700 FRONT/3500 REAR	5400	5450
Power requirement	KVA	25			30
Controller	FANUC	0i-M			

\*AVAILABLE CONTROLLER:SIEMENS/MITSUBISHI/HEIDENHAIN

## Control Panel OPTION



FANUC



SIEMENS



MITSUBISHI



# MACHINE SPECIFICATIONS

ITEM	MODEL	V-42iF/iR		V-42AF/AR	V-52AF/AR
		Type	Arm	Arm	Arm
A.T.C	Type				
CAPACITY	Unit				
X axis travel	mm (in)		1000(40)		1270(50)
Y axis travel	mm (in)		520(20.5)		520(20.5)
Z axis travel	mm (in)	610(24)		610(24)	610(24)
Distance from table top to spindle end	mm (in)		100-710(4-28)		100-710(3.9-27.9)
Distance from column front to spindle center	mm (in)		567(21.5)		567(22)
<b>TABLE</b>					
Table size (L x W)	mm (in)		1100x500(43.3x19.7)		1420x500(56x20)
Max. table load weight	kg		500		500(1102)
T-slot size	mm		18Tx100x5		18Tx100x5
<b>SPINDLE</b>					
Spindle speed	rpm		10000,12000		10000
Spindle nose (normal size, No.)			7/24 Taper, No.40		7/24 Taper,NO40
Spindle bearing inner diameter	mm(in)	60(2.36)		70(2.76)	70(2.75)
<b>FEED RATE</b>					
Rapid traverse X/Y/Z	m/min(ipm)		48/48/36(1890/1890/1417)		48/48/36(1890/1890/1417)
Max. cutting feed rate	m/min(ipm)		10(394)		10(394)
<b>A.T.C.</b>					
Tool storage capacity	pcs	24		24	24
Max. tool diameter(with adjacent tools)	mm(in)	80(3.15)		80(3.15)	80(3.15)
Max. tool length	mm(in)		250(9.8)		250(9.8)
Tool change time T-T/C-C	sec		1.8 / 4		1.8/4
<b>MOTORS</b>					
Spindle motor(30 min) FANUC	kw(hp)	11(14.7)		18.5(24.8)	18.5(24.8)
X/Y/Z axis motor	kw(hp)		4/4/4(5.4/5.4/5.4)		4(5.4)
<b>MACHINE SIZE</b>					
Height of machine (H)	mm(in)		2730(107)		2712(107)
Floor space (L x W)	mm(in)		2870x2560(113x101)FRONT/2440x3010(96x118.5)REAR		3100x3431(122x135)FRONT/2800x3638(110x143)REAR
Total machine weight	kg	5500		5550	5800
Power requirement	KVA	30		35	35
Controller	FANUC			0i-M	

\*AVAILABLE CONTROLLER:SIEMENS/MITSUBISHI/HEIDENHAIN

## Control Panel OPTION



FANUC

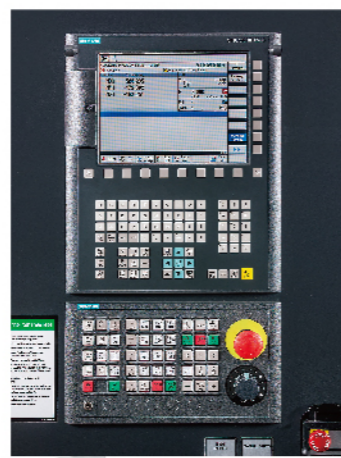

SIEMENS



MITSUBISHI

# MACHINE ACCESSORIES

ITEM	MODEL	V-22iF/iR	V-30iF/iR	V-32iF/iR	V-32AF/AR	V-42iF/iR	V-42AF/AR	V-52AF/AR
RS232		●	●	●	●	●	●	●
Full enclosure guarding		●	●	●	●	●	●	●
Work light		●	●	●	●	●	●	●
Alarm lamp		●	●	●	●	●	●	●
Heat exchanger		●	●	●	●	●	●	●
Rigid tapping		●	●	●	●	●	●	●
Auto counter for workpiece		●	●	●	●	●	●	●
Chip conveyor (auger type) + 2 chip buckets		●	●	●	●	●	●	●
Remote MPG		●	■	●	●	●	●	●
Spindle speed 8000rpm		●	●	■	■	■	■	●
FANUC control		●	●	●	●	●	●	●
Siemens control		■	■	■	■	■	■	■
Mitsubishi control		■	■	■	■	■	■	■
Spindle speed 10000rpm (steel bearing)		■	●	●	●	●	●	●
Spindle speed 12000rpm (ceramic bearing)		■	■	■	■	■	■	■
Spindle speed 15000rpm (DDS)		▲	▲	▲	X	▲	X	X
Spindle speed 15000rpm (DDS with CTS)		▲	▲	▲	X	▲	X	X
Spindle oil chiller		■	●	●	●	●	●	●
C.T.S. Form A		■	■	■	■	■	■	■
Tool tip air blow system		●	●	■	■	■	■	■
Tool overload detection		■	■	■	■	■	■	■
Tool management		■	■	■	■	■	■	■
Auto tool length measurement TS-27		■	■	■	■	■	■	■
Automatic workpiece measurement OMP-60		■	■	■	■	■	■	■
Chip conveyor outside machine & chip bucket		■	■	■	■	■	■	■
Chip disposal at the front		■	■	■	■	■	■	■
Chip disposal at the rear		■	■	■	■	■	■	■
Oil skimmer		■	■	■	■	■	■	■
Coolant gun		■	■	■	■	■	■	■
Air conditioner		■	■	■	■	■	■	■
4th axis rotary table preparation		■	■	■	■	■	■	■
4th axis rotary table		■	■	■	■	■	■	■
Manual chuck with connecting plate for rotary table		■	■	■	■	■	■	■
Manual tailstock for rotary table		■	■	■	■	■	■	■
Power disk for 4 axis rotary table		■	■	■	■	■	■	■
Through hole drill kit		■	■	■	■	■	■	■
DNC link software		■	■	■	■	■	■	■
Programmable nozzle		■	■	■	■	■	■	■
Programmable air blow		■	■	■	■	■	■	■
CTS preparation		■	■	■	■	■	■	■
Simple Filtrating system & 20bar /25u pump sys.		■	■	■	■	■	■	■
Simple Filtrating system & 40bar /25u pump sys		■	■	■	■	■	■	■
Sub tank		■	■	■	■	■	■	■
Extra coolant tank		■	■	■	■	■	■	■
Spindle annular coolant jet (Arm type ATC)		■	■	■	■	■	■	■
2 Speed gear box		X	X	■	■	■	■	■
Arm type ATC 30 tools		▲	▲	▲	▲	▲	▲	▲
Linear scale		▲	▲	▲	▲	▲	▲	▲
Surrounding coolant system		■	■	■	■	■	■	■
Auto door		▲	▲	▲	▲	▲	▲	▲

● : S.T.D / ■ : O.P.T (DESIGNED) / ▲ : O.P.T (TO BE ADVISED) / X : N/A(NOT AVAILABLE)